

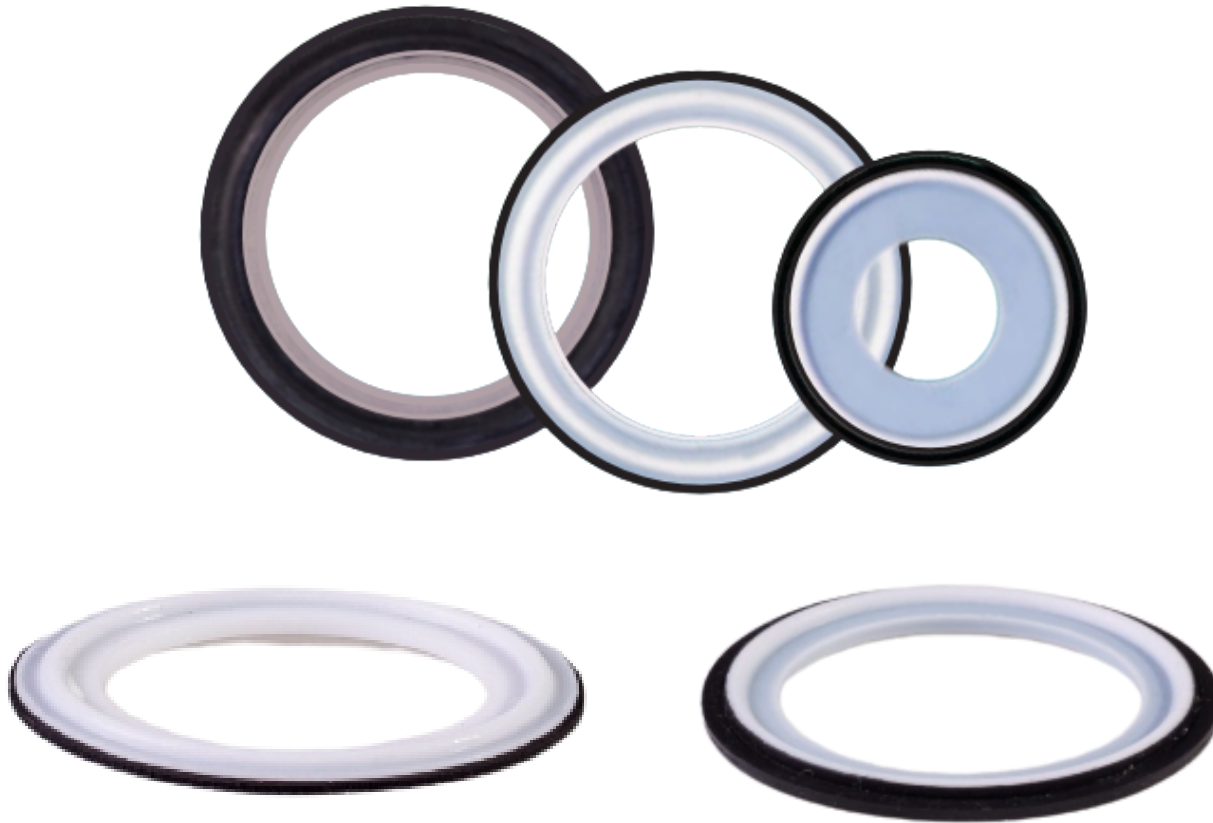

Fluid Path Products

Safety. Repeatability. American Made.



PTFE Sealing Solutions
Envelope Gaskets



ENVELOPE GASKETS

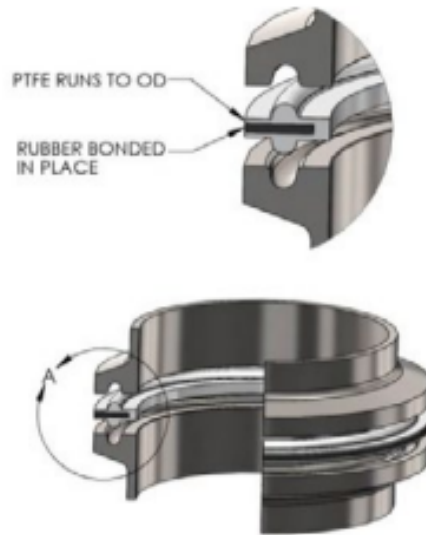
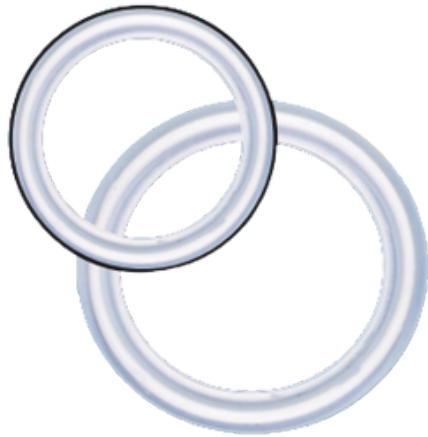

Envelope gaskets provide an inert, chemically resistant PTFE product contact surface, combined with the memory and compressibility of an elastomer inner core. Fluoro-Guard gaskets have multiple benefits including; enhanced sealing efficiency, flexibility, maintaining sealing performance under vacuum conditions and extended gasket life.

Fluid Path's Difference

- Our in-house engineering, design, and manufacturing allow for total control - Made in the USA
- Maximizes sealing efficiency in the process
- Made to ASME-BPE Standards
- Animal Derived Ingredient Free
- FDA Approved Materials
- USP Class VI tested
- ISO 10993 Compliant



COMPOUNDS THAT PERFORM ENGINEERED AND PROVEN TO OUTPERFORM THE COMPETITION

Fluid Path Products is an expert producer and blender of USP Class VI and FDA compliant Virgin and Modified PTFE Based Products. When your process demands purity, chemical inertness and uncompromised performance, we deliver solutions!

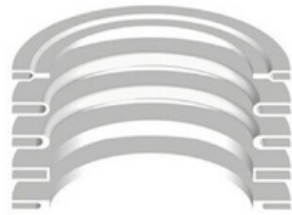

We manufacture a full line of standard and specialty USP Class VI and FDA compliant PTFE gaskets including:

- **PTFE Clamp Gaskets, in White and Colors**
- **Flanged PTFE Clamp Gaskets**
- **PTFE Envelope Gaskets**
- **Fluoro-Steel PTFE / 316L Stainless Gaskets, for optimum steam resistance**



IN-HOUSE ENGINEERING:

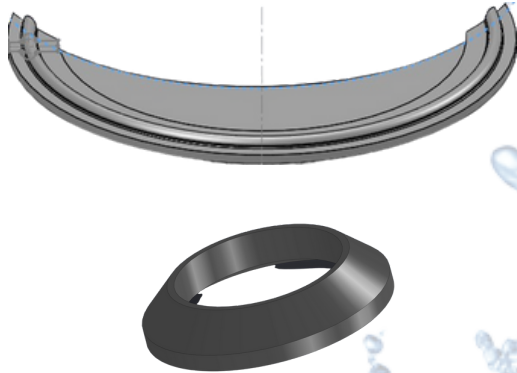

IN-HOUSE TOOLING DESIGN & DEVELOPMENT:

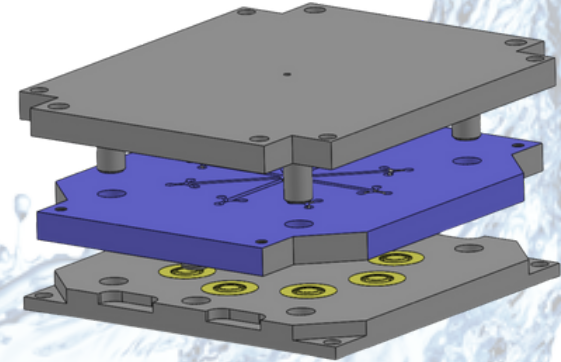

IN-HOUSE PRODUCTION:

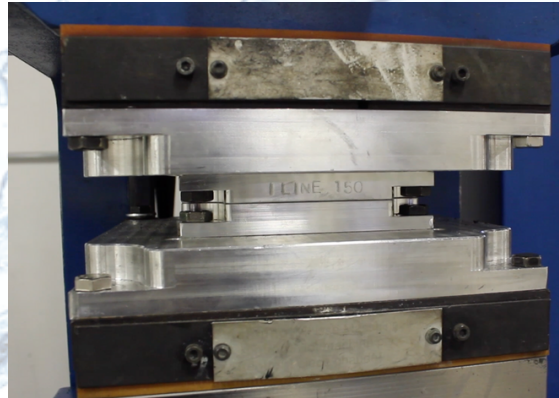

IN SERVICING THE INDUSTRY THE WAY IT SHOULD BE SERVICED WITH THE HIGHEST QUALITY AND PROCESS CONTROLS. SINCE THIS IS DONE IN-HOUSE, WE ACHIEVE BRINGING FINISHED PRODUCTS TO MARKET WITH THE GREATEST SPEED, EFFICIENCY, AND QUALITY.

